

Pressure Bell Systems Field Service Guide

PAC Overview

CSI's Pressure Activated Control (PAC) systems use a closed air system inside our patented pressure bell to detect water level. As the water level increases, the water pushes on the rolling diaphragm, increasing the pressure inside the bell and tubing. The end of the tubing is connected to an electronic pressure transducer that reads the air pressure inside the tubing. The PAC controller translates that air pressure into a water level, which compares to the user-defined setpoints to determine when to turn the outputs on and off.

Points to Keep in Mind

- All tubing connections must be made *before* the pressure bell is placed in the water. This effectively sets the “zero-level” state of the pressure bell to the correct level.
- Cut a fresh end each time you reconnect a piece of tubing to a plastic push-in connector or brass barbed connector. This will ensure an air-tight seal.
- Do not remove the tubing from the pressure transducer on the circuit board. The plastic transducer barb is fragile and can be broken or cracked when removing tubing. Use the pressure coupler on the end of the short factory-installed tubing.

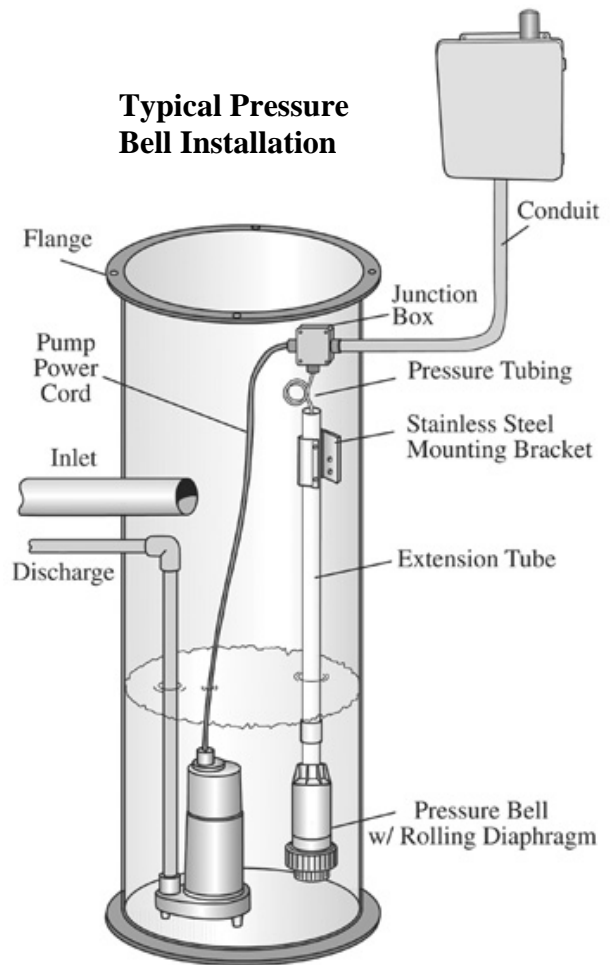

Pressure System Troubleshooting Steps

While these steps may not all apply to your particular installation, this general sequence of actions can help identify the cause of problems you may be having. For all these steps, you should leave your PAC controller powered up; however, you may shut off any pump circuit breakers.

1. If the PAC controller features a digital level readout, take note of the level before opening the top of the basin. (If it does not have a digital level readout, see step #6.)
2. Remove the lid from the basin, then check the level reading that is now on the digital level readout. If it decreased significantly, then your basin is most likely not properly vented. An airtight pump chamber can build up pressure as outside temperature and atmospheric pressure change. This causes the water level measurement to be inaccurate, which may cause the controller to call the pumps to run even in a low water situation, and/or can cause false high level alarms.
3. Compare the actual liquid depth to the digital level readout on the controller. They should match within a couple inches. (Keep in mind that the water level measured by the pressure bell is relative to the middle of the large union nut at the bottom of the pressure bell. If your controller has a programmable offset, that number will always be added to the depth measured from this point on the pressure bell.) If the actual level in the tank is significantly higher than is indicated by the display, it is possible that your pressure system has lost air over time. This is usually due to a slow leak at one of the tubing connections. See **Checking for Air Leaks** section below. If the actual level in the tank is significantly

lower than is indicated by the display, that means that your pressure system has gained air over time. In this case, you most likely have a pressure bell manufactured before August 1, 2007. Bells manufactured after that date have a small slit cut into the diaphragm to allow excess gases that may permeate the nitrile rubber membrane to escape. See August 1, 2007 “Pressure Bell Slit Change” letter for more details.

4. Pull the pressure bell up out of the water. Look up in the bottom of the pressure bell. Make sure there is not an excess amount of debris that is preventing the rolling diaphragm from freely moving up and down. Make sure the diaphragm is seated correctly against the push cup inside the pressure bell (see images below).

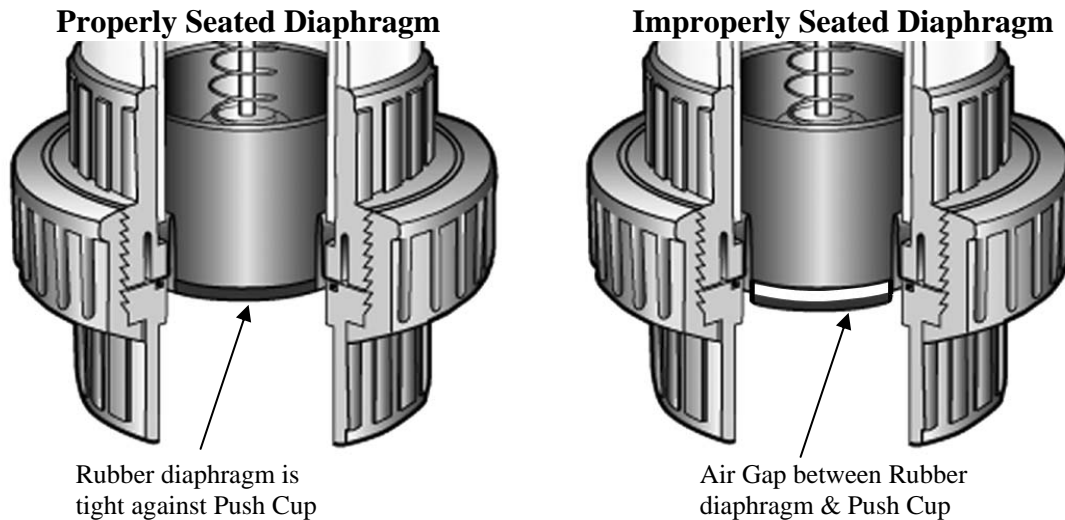

If the diaphragm is not properly seated, see the **Reseating the Diaphragm** section below. A pressure bell which has gained air over time but does not have the small slit cut in the diaphragm may gain enough air to push the diaphragm out to its extents, making it look like a balloon or rubber ball. This can be fixed by reseating the diaphragm.

5. Disconnect the tubing from the top of the pressure bell, leaving the other end of the tubing still connected at the control panel. Now check the displayed level to see if it changed at all. It should have dropped down to zero. If it did not, there is most likely water in the pressure tubing. To be sure, disconnect the tubing now at the control panel. (Disconnect the tubing from the coupler fitting in the control panel, not from the circuit board transducer itself.) If the displayed level drops down to zero, then there is definitely a blockage in the tubing. Because the air pressures at work are so low (four feet of water creates only about 1.4 psi), a small droplet of water that blocks the 1/8" inside diameter of the tubing will prevent pressure changes in the pressure bell from propagating up the tubing to the pressure transducer on the circuit board. To fix this, either remove as much water from the tubing as possible (a small air compressor usually works well for this purpose) or replace the tubing.
6. Move pressure bell side to side while holding it to test for water inside. If water has leaked into the pressure bell, you should be able to feel and hear it sloshing around inside the housing. If there is water in your pressure bell, disconnect the tubing from the fitting on the pressure bell, turn the bell upside down, and pour out as much of the water as possible before reinstalling the pressure bell.
7. Note: If your PAC controller does not feature a digital level readout, you can still approximate the perceived level reading when needed. To do this, you will need to adjust some level setpoints, so turn off any pump circuit breakers in your control panel so that your pump does not turn on as you make adjustments which would lower the actual water level. First, take note of the current setting of each level setpoint dial or slider, so that after you are finished troubleshooting, you can set them back to their proper levels. Then very slowly adjust the setpoints up or down just until the corresponding output turns on or off. Wherever the dial or slider is at the time the output changed, that is the water level that the controller “thinks” is in the basin. Typically, a high level alarm output is best suited for this purpose.

Reseating the Diaphragm

The proper operation of the rolling diaphragm assembly is key for the proper operation of the pressure system. For the diaphragm to be seated, it must be snug around the push-cup inside of the pressure bell assembly. A diaphragm that is not seated properly must be reseated. This can be done one of three ways. (For the Fist and Vacuum Pump methods, it can be helpful to have a second person present to assist you.)

Vacuum Pump Method

(This method is the most reliable way to verify a diaphragm is seated correctly, and is the most convenient method to use when a reseating the diaphragm on a pressure bell which has already been installed.)

With the pressure bell up out of the water, connect the pressure tubing to the pressure bell's tubing fitting, leaving the other end of the tubing open. Connect a handheld vacuum pump to the open end of the pressure tubing. The type of pump used for bleeding automotive brake lines works well, such as the Mityvac MV8000 or AutoZone's part number 25136. (Use of the reservoir jar is optional.) Use the hand pump to remove air from inside the pressure bell, while also observing the position of the rolling diaphragm. Keep pumping until the diaphragm has reached its fully-inverted limits (this may take approximately 60 hand pumps, and may vary depending on your vacuum pump model). If necessary, adjust the diaphragm so that it is flat against and centered on the push cup. Then disconnect the vacuum pump from the tubing. The internal spring will push the diaphragm down slowly as it draws air back into the pressure bell. Once the diaphragm is finished moving down (may take a minute or two), make sure the pressure tube is reconnected to both the pressure bell and the controller *before* the bell is submerged in liquid.

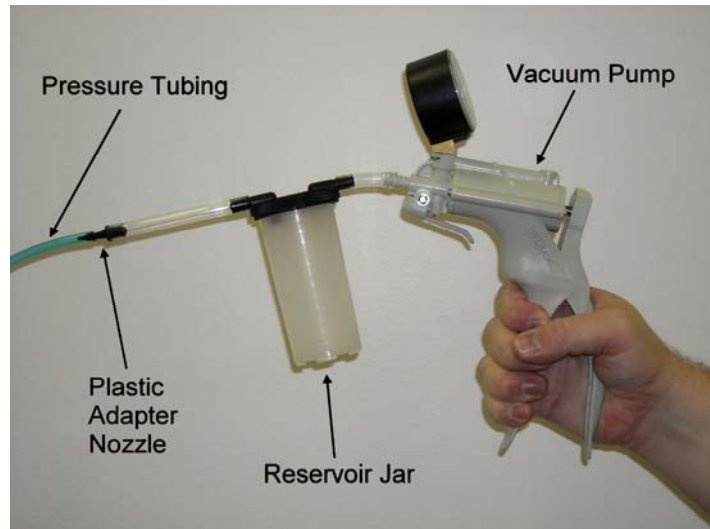

Fist Method

With the pressure bell up out of the water, connect the pressure tubing to the pressure bell's tubing fitting, leaving the other end of the tubing open. With your fist, slowly push in the rubber diaphragm. Air will exit the tubing as the diaphragm moves up inside the pressure bell. When the diaphragm is fully pushed in with as much of the air pushed out as possible, cover the end of the tubing with your finger. Then remove your fist and observe the diaphragm, which should stay sucked up inside the pressure bell. Adjust the diaphragm so that it is flat against and centered on the push cup. Then remove your finger from the end of the tubing, and the internal spring will push the diaphragm down slowly as it draws air back into the pressure bell. Once the diaphragm is finished moving down (may take a minute or two), make sure the pressure tube is reconnected to both the pressure bell and the controller *before* the bell is submerged in liquid.

Pressure Bell Reseating Procedure for "Vacuum Pump Method" and "Fist Method"

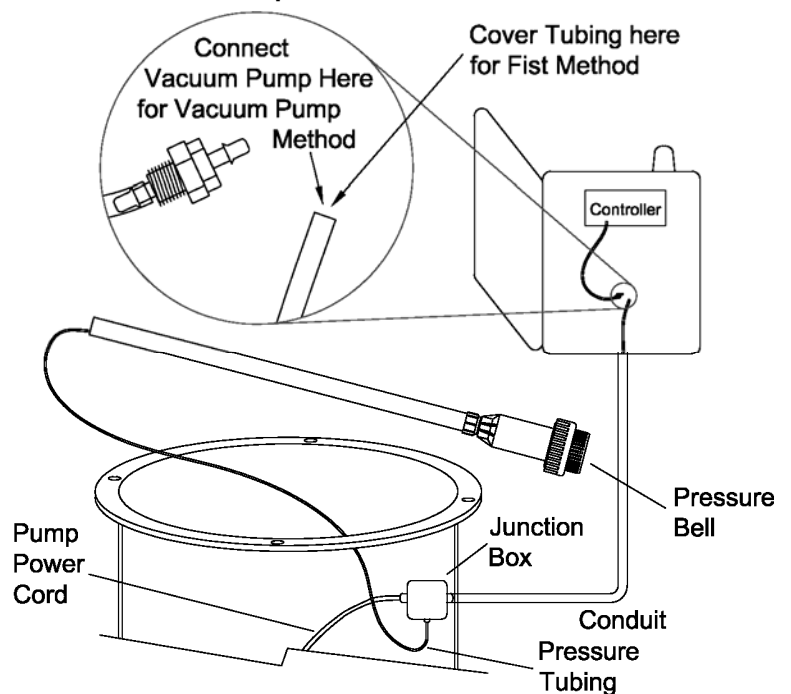

Pressure Bell Reseating Procedure for "Plunging Method"

Plunging Method

Reseating the diaphragm can be accomplished by slowly plunging the pressure bell into a liquid depth of about three feet. This must be done *without* the pressure tube connected to the controller, but with the tube connected to the pressure bell itself. Then pull the pressure bell back up and verify that the diaphragm has seated properly. Once the diaphragm is reseated, the rubber will be snug around the internal push-cup and when lightly touching the diaphragm the push-cup can be felt immediately behind the diaphragm. It may take several times of plunging the pressure bell in the water to successfully seat the diaphragm, so repeat if necessary. Make sure the diaphragm has fully returned to its normal position; this may take up to a minute as the spring pushes the diaphragm down, drawing air back in through the tubing. Then reconnect the pressure tube to both the pressure bell and the controller *before* the bell is submerged in liquid.

Checking for Air Leaks

CSI Controls' pressure bell systems must be completely airtight to work properly. Even a very tiny, nearly undetectable air leak will cause a problem over a period of months or years. Air leaks this small can be difficult to detect. But if you suspect you have a slow air leak and your controller features digital level readout, then it is possible to at least detect

whether that air leak is located right at the circuit board, or somewhere farther down the line. First, make sure your pressure bell is properly seated and installed in a significant depth of water. Then kink the tubing back on itself approximately 6 inches from the circuit board. This creates a good seal and essentially reduces the entire air system (as far as what the pressure transducer sees) to that small 6 inches of tubing. If there is an air leak at the transducer barb connection, or in the transducer itself, the small volume of air means that the pressure will drop off very quickly compared to when the total volume of the pressure bell and full length of tubing is part of the system. Watch the level readout to see if it slowly decreases as air leaks out. The level will show minor variations up and down because of slight changes in how you hold the tubing, and may warm the air inside the tubing. Use a zip tie (as shown on right) or tape to keep the tubing kinked to eliminate some of these variations.

However, if there is a leak at the transducer, you will see a slow, steady decrease in the displayed level over a period of approximately five minutes. If after five minutes, the displayed level has remained substantially the same, then there is not an air leak at the pressure transducer. Make sure the tubing is fully pushed onto the transducer barb, and that it has not been damaged. It is possible that the transducer itself is leaking air. If you have determined that the transducer itself is leaking air, the only solution is to replace the controller.

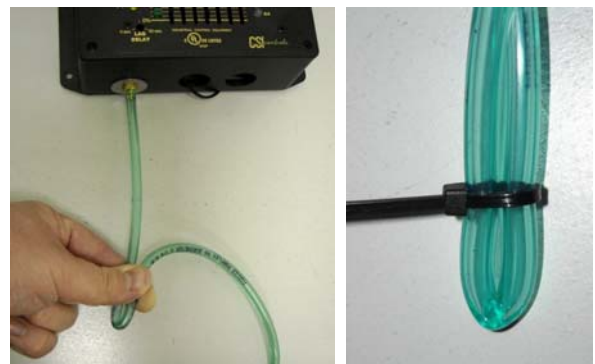
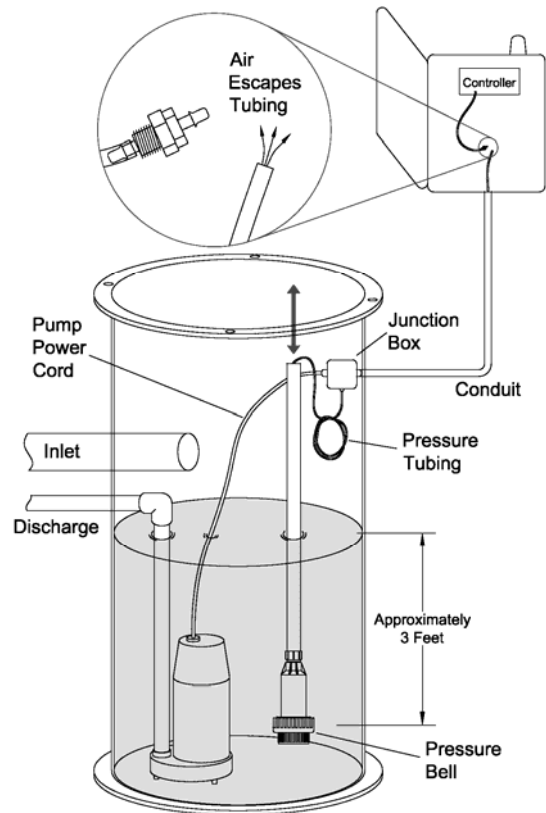

220 Ohio Street, Ashland, OH 44805
(800) 363-5842 • www.CSIcontrols.com