

# Smart Start™ MPM Installation Instructions

The Smart Start™ Motor Power Module is a complete motor starter designed for single phase motor applications that use external Start/Run capacitors. The Motor Power Module combines the functions of the conventional motor contactor, overload module, and motor start relay into one component. The Motor Power Module is designed to protect the motor start capacitor from failing, provide overload as well as undercurrent protection, be more responsive and precisely control motor boosting during heavy load conditions. See features section for complete list of features designed into the Smart Start™ Motor Power Module.

SPECIFICATIONS		FEATURES
<b>ELECTRICAL</b>		<ul style="list-style-type: none"> <li>Combines the functions of a Motor Contactor, Motor Overload, and Start Relay into one compact unit</li> <li>Zero Cross Technology allows the relay to run a higher power load</li> <li>Controls the start circuit to protect the capacitor and increase pump performance</li> <li>Advanced motor protection and monitoring provides for:               <ul style="list-style-type: none"> <li>Pump overload protection</li> <li>Pump undercurrent protection</li> <li>Low incoming voltage protection</li> </ul> </li> <li>Monitors start capacitor usage and keeps it in safe operating range</li> <li>The fault output contacts normally open or normally open held closed</li> <li>Auxiliary normally open contacts</li> <li>18 Month Limited Warranty</li> </ul>
Input Power	115-240Vac, 1Φ, 60Hz	
Motor FLA:		
MPM-020	5A - 20A	
MPM-030	15A - 30A	
MPM-020 HP Rating:		
115V	1.5	
230V	3.0	
MPM-030 HP Rating:		
115V	2.0	
230V	5.0	
Short Circuit Rating	5kA	
Overload	Class 10	
Power Consumption	4.5W max.	
Impulse Rating:	$U_{imp}$ : 4kV	
Aux/Fault Output Rating (non-powered, dry contacts)	0.3A 120 VAC max.	
A1, A2 (start/stop input)	100-250 VAC	
Agency Approvals	UL/cUL	
Operating Temperature	-40°F to 140°F	
<b>MECHANICAL</b>		
Dimensions:		
Inches	1.8 x 3.1 x 4.2	
Millimeters	45.7 x 78.7 x 1.67	
Terminal Torque:		
Power Terminals	15 in lbs	
Control Terminals	6 in lbs	
Weights lbs (g)	.48 (218)	
Max. Conductor Size:		
Power Terminals	8-14 AWG	
Control Terminals	16-30 AWG	
Mounting	DIN Rail/Backplate	
<b>Product Notes:</b> <ul style="list-style-type: none"> <li>For indoor use only or in controlled enclosed environments.</li> <li>The MPM is designed and approved for use only with motor start capacitors that are in compliance with standard EIA 463.</li> <li>The MPM is only for use on approved pumps. Warranty will be void if used on unapproved pumps.</li> <li>Critical control systems should always have a backup alarm and/or operation.</li> </ul>		



U.S. Patents 7,151,459; 7,746,237;  
other patents pending.

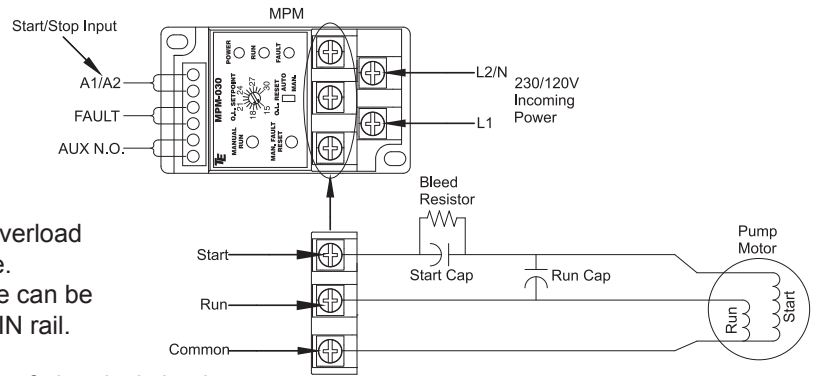

1. Verify that the FLA rating of the motor is within the overload setting shown on the top of the Motor Power Module.
2. Secure the MPM to the panel backplate. The module can be screwed directly to the backplate or installed onto DIN rail.
3. Make electrical connections per the wiring diagram.

**Note:** The bleed resistor is necessary to prevent risk of electrical shock.

4. If necessary change the fault output from normally open (default) to normally open held closed. See instructions below.
5. Determine the FLA of the pump and adjust the Overload setpoint dial located on top of the module accordingly.
6. Adjust the Overload Reset switch to Auto or Manual as desired.
7. Apply power and cycle the system to verify it is operating correctly.

The Fault Output can be configured to be normally open (NO), close on fault, or it can be configured to be normally open held closed (NOHC), open on fault (or power fail). To configure this output, press and hold the Fault Manual Reset pushbutton while powering the unit up. After two seconds the run and fault LED's will alternately flash twice, indicating the setup mode has been entered. While continuing to hold the Reset pushbutton move the O.L. Reset slide switch to the Automatic position in order to set the Fault contact to NOHC. Or move the slide switch to the Manual position in order to set the contact to NO. The Fault relay state will be saved once the Reset pushbutton is released. Once the Reset pushbutton is released, be sure to return the O.L. Reset slide switch to the position desired for overload reset operation.

**TROUBLESHOOTING**

The Smart Start™ Motor Power Module provides a fault light that is used to indicate if a fault condition has occurred. The flash code is used to identify what type of fault has occurred. Below are the flash codes with associated faults that cause them.

FLASH SEQUENCE	FAULT CONDITION
On Solid (no flashing)	Overload Fault Occurred but is now clear, waiting for a manual reset. (This can occur only when the O.L. Reset switch is set to manual).
One flash every two seconds	Overload Fault Active (Cannot be cleared by pressing the reset push button or by cycling power. It will clear only by waiting for it to "cool down".)
One Flash every six seconds	Low Current fault. Low current is set to trip at 62.5% of the overload set point. The motor current must be below this set point for four seconds for the Low Current fault to activate. Low current trip uses the Intelli-Trip™ feature. During the Intelli-Trip™ sequence after being tripped in low current for 5 minutes the Low Current fault will automatically reset.
Two Flashes every six seconds	Start Circuit Failure. This can be caused by a mis-wired start circuit/pump, by failed capacitors in the start circuit, or an internal failure in the MPM. Double check all circuit and pump wiring to verify proper connections and components, and check the capacitors that they are functioning correctly. Start Circuit Failure trip uses the Intelli-Trip™ feature. During the Intelli-Trip™ sequence after being tripped in Start Circuit Failure for 5 minutes the fault will automatically reset.
Three Flashes every six seconds	Low Voltage fault. Low Voltage is automatically set based on the incoming line voltage. Nominal rated voltages are 115V, 208V and 230V. Low Voltage will trip when the line voltage drops 10% below the nominal rated voltage. The Low Voltage fault uses the Intelli-Trip™ feature. During the Intelli-Trip™ sequence, the Low Voltage fault will be automatically reset when the voltage returns to be 5 volts above the trip value. Also, to manually reset this fault the voltage must be 5 volts above the trip value.
Four Flashes every six seconds	No Current sensed at start-up. The No Current fault can occur if the motor load to the MPM has been disconnected. This fault can also mean a failure of the internal contacts of the MPM, or the current sensor. This fault can be reset so the MPM can try to start again by pressing the Man. Fault Reset button, or by cycling the line power to the MPM.
Five Flashes every six seconds	Internal fault. If this should occur, attempt to clear the fault by cycling power to the MPM.
Intelli-Trip™	The Intelli-Trip™ feature will automatically reset the fault after 5 minutes, or after conditions return to normal, for the first two occurrences of the same fault. On the third occurrence of the same fault, the fault will latch in until the Fault Manual Reset push button is pressed, or line power to the MPM is cycled off and then back on. If the pump shuts off automatically (run signal is removed) at any point in the Intelli-Trip™ sequence the sequence is reset.