

ELECTRICAL WARNINGS

⚠ WARNING

ELECTRICAL SHOCK HAZARD

Disconnect power before installing or servicing this product. A qualified service person must install and service this product according to applicable electrical and plumbing codes.

⚠ WARNING

EXPLOSION OR FIRE HAZARD

Do not use this product with flammable liquids. Do not install in hazardous locations as defined by National Electrical Code, ANSI/NFPA 70.

Failure to follow these precautions could result in serious injury or death. Replace product immediately if switch or cable becomes damaged or cracked. Keep these instructions with warranty after installation. This product must be installed in accordance with National Electric Code, ANSI/NFPA 70 so as to prevent moisture from entering or accumulating within boxes, conduit bodies, fittings, float housing, or cable.

For detailed specifications on this product, or for the complete line of CSI Controls® panel, alarm, and switch products, visit our website at www.csicontrols.com.

A Pump Switch is designed for Horsepower (HP) rated loads and is not suitable for control (pilot duty) applications. It will fail prematurely when switching loads less than 1 Amp at 120 VAC. Select a float switch from our Control Switch offering for control applications.

PREVENTATIVE MAINTENANCE

- Periodically inspect the product. Check that the cable has not become worn or that the housing has not been damaged so as to impair the protection of the product. Replace the product immediately if any damage is found or suspected.
- Periodically check to see that the float and rod are free to move and operate the switch.
- Use only CSI Controls® replacement parts.

NOTICE!

Products returned must be cleaned, sanitized, or decontaminated as necessary prior to shipment to ensure that employees will not be exposed to health hazards in handling said material. All applicable laws and regulations shall apply.

MEDIUM DUTY LIMITED SPACE Pump Switch

Installation Instructions

1023632C 05/22

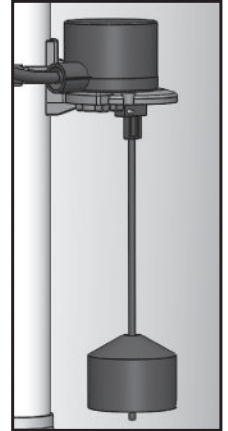
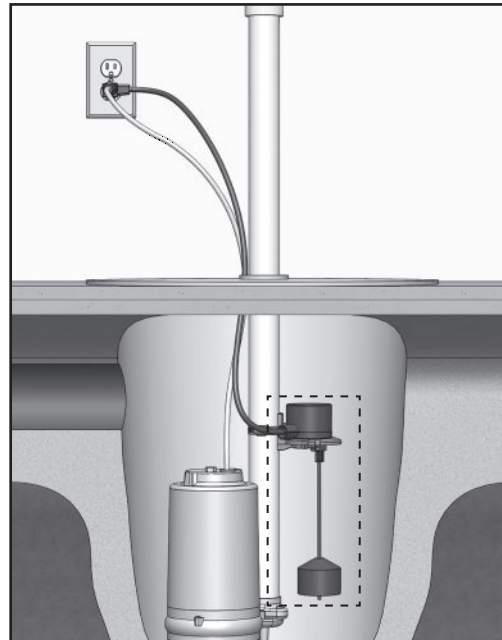

MEDIUM DUTY LIMITED SPACE PUMP SWITCH

This mechanically activated pump switch is designed for direct control of pumps in non-potable water and sewage applications. It works well in applications with limited space such as: small sump chambers, effluent applications, and laundry trays, as well as in large tanks.

The Medium Duty Limited Space pump switch is not sensitive to turbulence.

It is available for pump down applications only.

CSI CONTROLS® FIVE-YEAR LIMITED WARRANTY

Five-Year Limited Warranty.

For complete terms and conditions, please visit www.csicontrols.com.



CSI Controls®

Technical Support: +1 800-746-6287

techsupport@sjeinc.com

www.csicontrols.com

Technical Support Hours: Monday - Friday, 7 A.M. to 6 P.M. Central Time

PN 1023632C 05/22
© 2020 SJE, Inc. All Rights Reserved.
CSI CONTROLS is a trademark of SJE, Inc.

1 Determine location for pump switch.

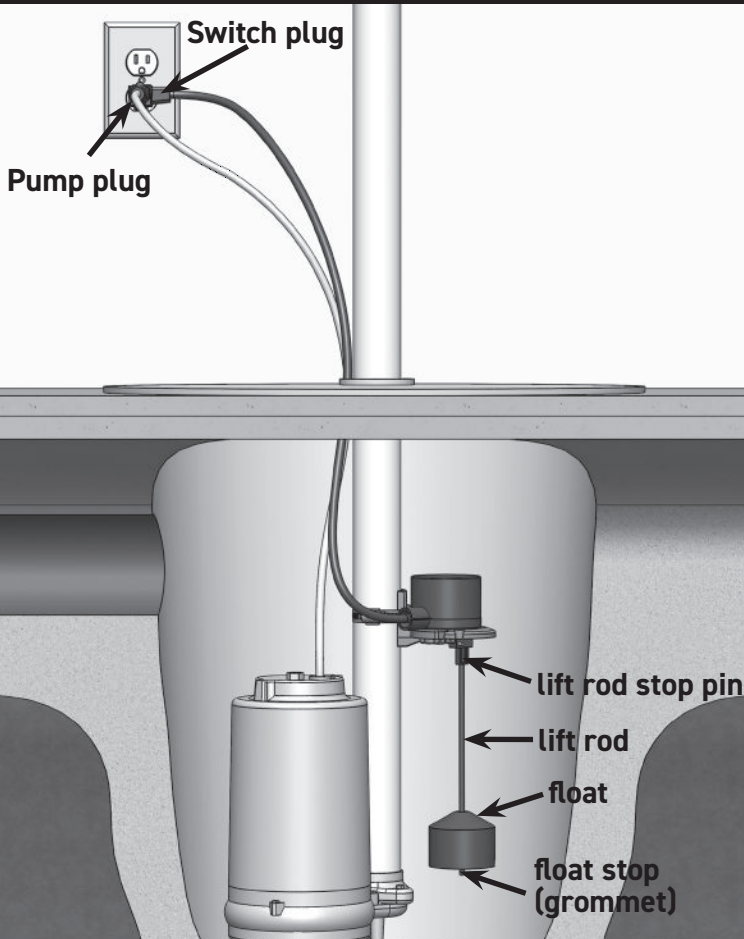

2 Secure pump switch to discharge pipe by inserting the hose clamp through the mounting bracket slots and tightening the hose clamp.

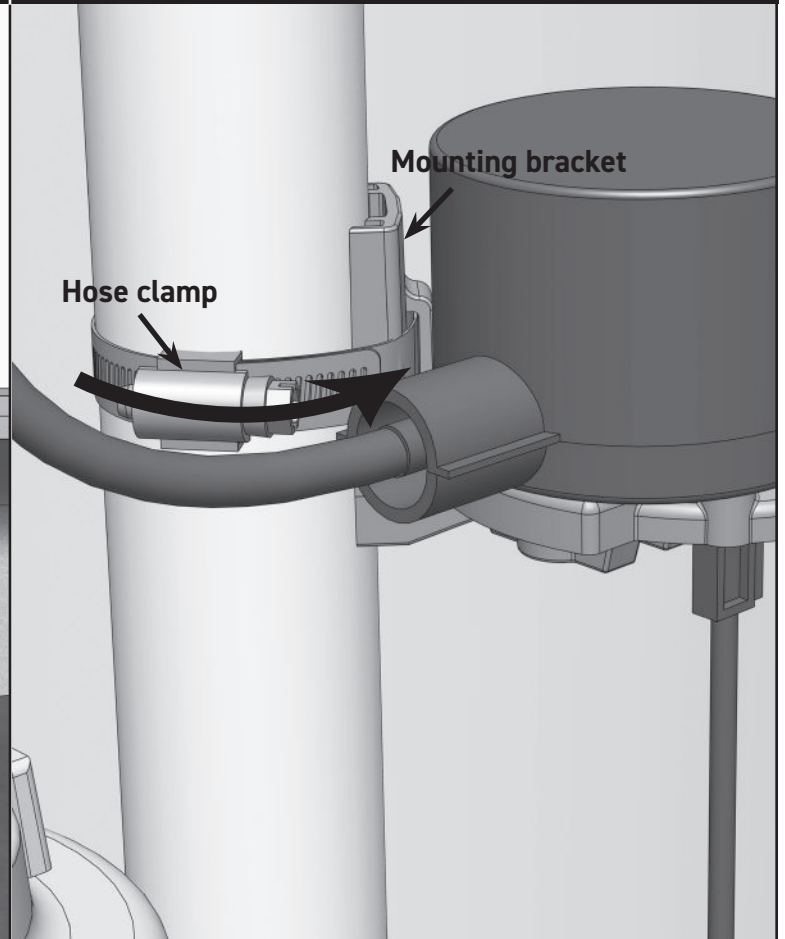

3 Adjust pumping range.

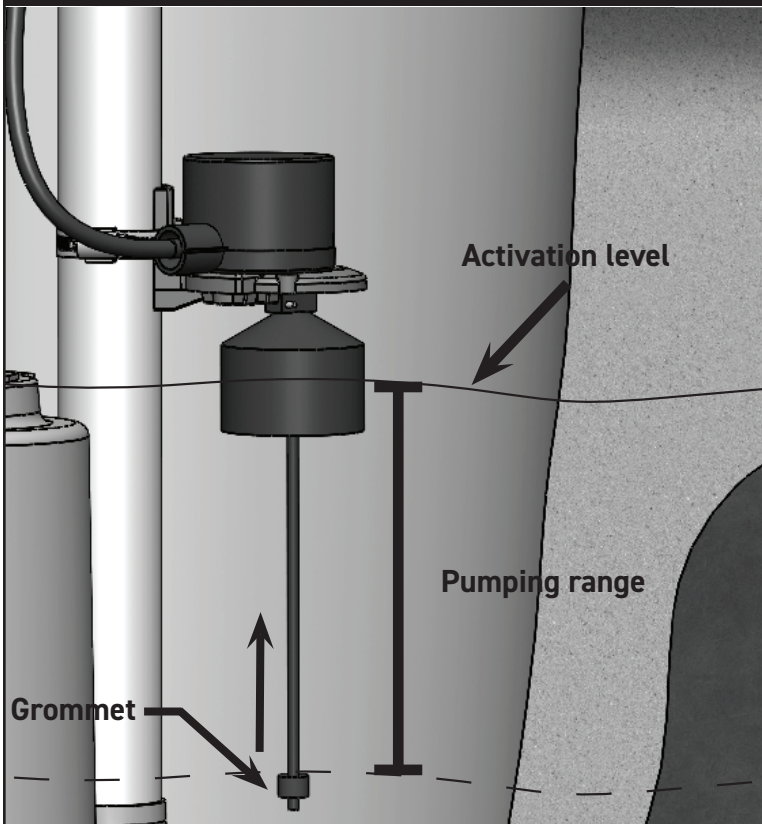

4 For units without plugs, connect wires as shown.

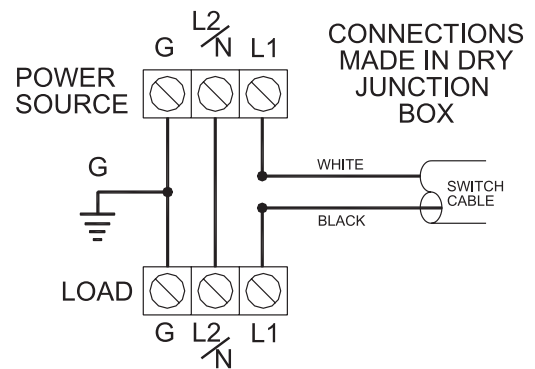

⚠ WARNING



In 230 VAC installations, one side of the line going to the load is always **HOT**. This condition exists if the switch is on or off. Install double pole disconnect on all 230 VAC circuits. Ensure cable connections are performed in a **dry** junction box or other watertight seal that seals both conductors and cable jacket. Failure to do so could result in electrical shock hazard and/or water traveling down cable and entering the switch. Failure to guard against this may affect switch performance.